

# Operating Manual

AdirPro HV8RL Red Beam Horizontal/Vertical Laser level



## Maintenance and Safety

The HV8RL is a class II laser according to 21CFR1040. Be careful not to expose your eyes to the laser beam. Direct exposure to the laser beam for a long period of time may be hazardous to your eyes.

Do not try to dismantle the instrument by yourself. Have it repaired by your dealer or supplier. Dismantling it by yourself may worsen the problem and void your warranty.

When mounting the instrument to a tripod, make sure the instrument is securely fixed. The tripod leg clamps should be securely fastened. If it is not securely fastened or tightened, the main unit can fall off and/or the tripod could fall over.

Always clean the unit after use. Use a clean cloth moistened with a neutral detergent or water.

Make sure the unit is completely dry before storage. Store the unit in the included carrying case with cushioning material. Make sure it is not subject to vibration, dust, high moisture or extreme temperature. The unit may not function properly if used out of the normal temperature range.

When transporting the unit, be careful to avoid impact or vibration.

Before starting to work, check that the unit is functioning correctly.

Do not attempt to charge standard alkaline batteries or the warranty will be voided.

Do not disassemble the unit. In case of inappropriate repairs, laser radiation may arise in excess amounts and liability may be incurred if there is damage. In cases of inappropriate processing, malfunctions are possible without external visible damage.

This unit contains nickel-metal hydride batteries. Nickel-metal hydride batteries must be recycled or disposed of properly. WEEE-Reg: DE23874031



Your HV8RL Unit includes the following:

- HV8RL Main Instrument
- Detector (LD-8) and Bracket (BR-8)
- Remote Control (RM-8)
- Charger (FC100)
- Target
- Glasses
- Hard Case with Foam Insert (FCC300)
- Extra Alkaline Battery Pack c/w 4xAA alkaline batteries (FBP100).
- Wall Mount Bracket

**Please contact your dealer if any of the above parts are missing.**

# Find your way around the HV8RL



# Control Panel

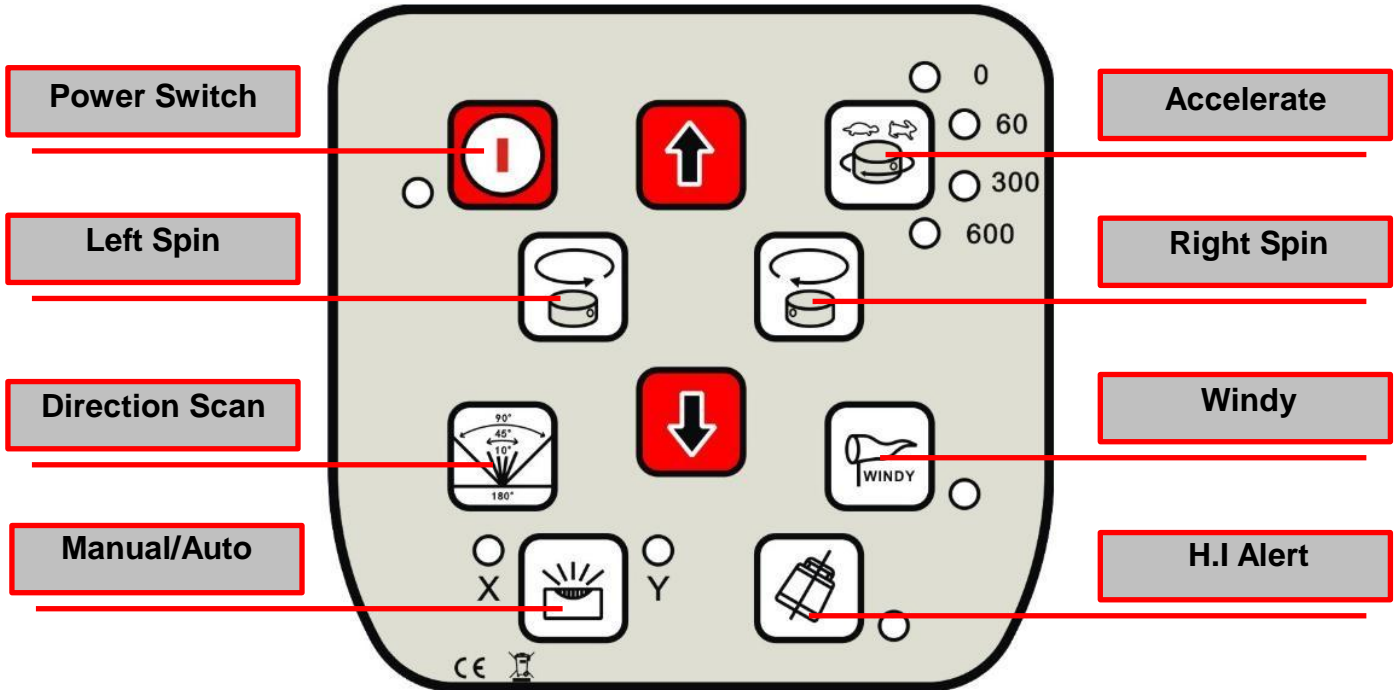

## Operation of Panel

**Power Switch:** Turns the unit on and off.

**Power Light:** When the red light is on, the instrument is on.

**Manual/Auto:** After being powered on, the unit will enter into self leveling mode. Press “Manual/Auto” once, and the device will enter into manual mode. Now the slope of Y-axis can be adjusted by the up and down arrows on the keypad panel. While pressing “Manual/Auto” again, the slope on X-axis can be set up by the two arrows on the panel. During this time, the other functions such as scanning, left spin or right spin are also available but without accuracy. When pressing “Manual/Auto” the third time, the laser will go back to Auto-level mode and will self-level again.

**Manual/Auto indicator:** When the Y indicator lights-is on, the slope of the Y axis can be adjusted. When the X indicator turns on, the X-axis slope can be adjusted.

**Accelerate:** To change the speed of the rotating beam, press this button multiple times to adjust the speeds to 0rpm, 60rpm, 300rpm and 600rpm.

**Tilt/H.I Alert:** Enabling this mode warns the user if the laser level has been jolted.

**Tilt Indicator:** When the light is blinking slowly, the laser is in H.I alert mode. When the light is blinking quickly,

the laser level will not level as it has been jolted.

**Directional Scan:** Circling knob. Angle of scanning includes 5 levels: 0-10°-45° -90°-180°

**Left Spin:** Allows the laser beam to step/move counter-clockwise. Unit must be in 0 RPM or scan mode.

**Right Spin:** Allows the laser beam to step/move clockwise. Unit must be in 0 RPM or scan mode.

**Up & Down Arrows:** Adjust the slope for both axes by working together with Manual/Automatic button.

**Windy:** Laser will be in continuous rotating/self-leveling mode during high winds, heavy vibrations, and shocks. The Windy mode will not affect the accuracy.



## **Directions:**

### **Battery Installment**

Both rechargeable and alkaline battery packs can be used for this laser. To replace the batteries, follow these instructions:

1. Unscrew the bolt at the bottom of the base. Take out the battery pack. The laser is officially c/w a Ni-Mh battery pack.
2. Place the battery pack into the port according to the right electrode.
3. Re-screw the bolt at the bottom of the base.

### **Instrument Placement**

#### **Horizontal scanning**

Place the instrument on a tripod or stable flat surface, or hang it on a wall. Set the unit upright, and keep the slope of the instrument within the range of  $-5^{\circ}$  to  $+5^{\circ}$  self-leveling range.

#### **Vertical scanning**

Place the instrument on a flat surface, and keep the slope of instrument within the range from  $-5^{\circ}$  to  $+5^{\circ}$ ,

## Operations

### Power

Press the ON/OFF key to switch the laser on. If the power indicator light blinks, the voltage of the batteries is low and batteries need to be replaced or recharged.

### Leveling

The Unit will automatically level when you turn it on. The leveling process is indicated by a blinking LED light. After being leveled, the laser rotating head will rotate at the speed of 600 RPM.

If the instrument is placed improperly, or the slope of instrument exceeds the range of  $-5^{\circ}$  to  $+5^{\circ}$ , the mode indicator and the laser beam will blink at the same time.

**Note: The instrument will shut down automatically if the unit exceeds the self-leveling system range for more than 5 minutes.**

### Spinning

#### Continuous spinning

Press the “Rotational speed adjustment” key to control the spinning speed of the laser. By pressing the key repeatedly, the spinning speed of the laser will continuously change to: 0rpm, 60rpm, 300rpm and 600rpm.

### Stepping spinning

Adjust the “High Speed” Key at the speed of 0 rpm, and the laser will stop spinning. Press the “Right Spin” key and the laser will step-move clockwise. Then if you press the “Left Spin” key, the laser will step-move counter-clockwise.

### Directional scanning

Adjust the “High Speed” key at speed of 0 rpm, the laser will stop spinning. Press the “Direction Scan” key and the laser will scan directionally. If you press the key repeatedly, the angle of scanning of the laser will continuously change as follows:  $0^{\circ}$ - $10^{\circ}$ - $45^{\circ}$ - $90^{\circ}$ - $180^{\circ}$ - $0^{\circ}$ .

Press the “Left Spin” key or the “Right Spin” key to change the direction of scanning.

### Slope Adjustment

When the unit is upright for horizontal rotation, the slope of the X-axis and Y-axis can be adjusted by using manual mode. Press the “Manual/Auto” key, and the unit will first enter into the mode of manual adjustment. The Y indicator lights.

#### Slope of Y-axis



a. Aim the Y1-beam to the direction of the slope required.

b. Press the  or  arrow to move the beam/line gets to its required position.

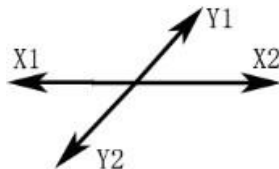
laser beam up or down until the



### **Slope of Y-axis**

- a. Press “Manual/Auto” again to switch laser into X axis. At this time, the X indicator will light up. Aim the X1-beam to the direction of the slope required.
- b. Press the  or  arrow to move the laser beam up or down until the beam/line gets to its required position.

### **Quit slope adjustment mode**

Press “Manual/Auto” key again. After both indicators (X&Y) goes off, the instrument will quit the slope adjustment mode/manual model and will self-leveling again.

## Vertical Lines



Place the Unit in the position shown above; press the button on the bottom left hand side of the panel. The instrument will Auto level and start spinning giving a Vertical beam.

## Power



Insert the charger into the charging socket of the main unit or the battery pack. Turn on the power. The charger will show one of 3 modes.

- Red flashing light - Battery not charging
- Red light - Battery on charge
- Green light - Battery charged

If the red light is on, check the connection.

If the red light is flashing please wait for charging to complete.

Once the green light shows, the instrument is fully charged and is ready for use.

Charging normally takes 7 hours and provides 20 hours of use.

Either Ni-Mh battery pack (the standard one) or Alkaline battery pack is available to work as a power supply.

**Notices:**

**(1) Using the standard rechargeable batteries of the instrument, recharging will be finished within 8 hours.**

**(4x5000mAh Ni-Mh batteries)**

**(2) Power required for the charger: Frequency: 50-60HZ; Voltage: 85-265V.**

**(3) You can simultaneously charge and use the unit at the same time.**

**(4) If you leave the unit unused for a long time, the batteries (dry battery or rechargeable battery) need to be removed before storage.**

**(5) Brand-new rechargeable batteries or long-time unused rechargeable batteries need to be recharged and drained three times to attain the capacity required.**

## RM-8 Remote

The remote control of the instrument uses infrared technology.

Aim the aperture of the infrared ray to the instrument (as depicted below) to bring the remote control into function. Available distance: indoor: 100 feet (30m); outdoor: 65 feet (20m). The keypad panel includes 9 keys; the indicator on the RC will blink to show the operating signal has been sent out once pressing any key.

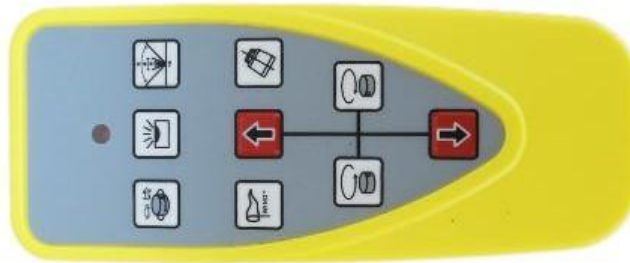

The remote can fulfill the following functions:

- (1) Spinning.
- (2) Directional scanning.
- (3) Slope adjustment.



## LD-8 Rotary Detector

The detector will pick up a spinning beam when it crosses the electronic sensor window.

The detector has 3 buttons:

- a) On/off button
- b) Sound button: with 3 settings – off – low – high
- c) Sensitivity button: will give either a narrow or a broader range of detection.

When the detector is too high, a slower beep will be emitted. When too low, a fast beep will be emitted. When it is leveled, a continuous pitch will sound - at this point the center of the detector is at the same alignment as the beam.

To get accurate results use the built-in bubble to keep the detector leveled.

The detector is powered by a standard 9v battery.



## Accuracy Checking

Follow these instructions for checking axis accuracy.

### Horizontal-surface Checking

1. Place the unit approximately 160 feet (50m) in front of a wall, and then adjust the level of the base approximately to aim the X1 to the wall, as shown below:

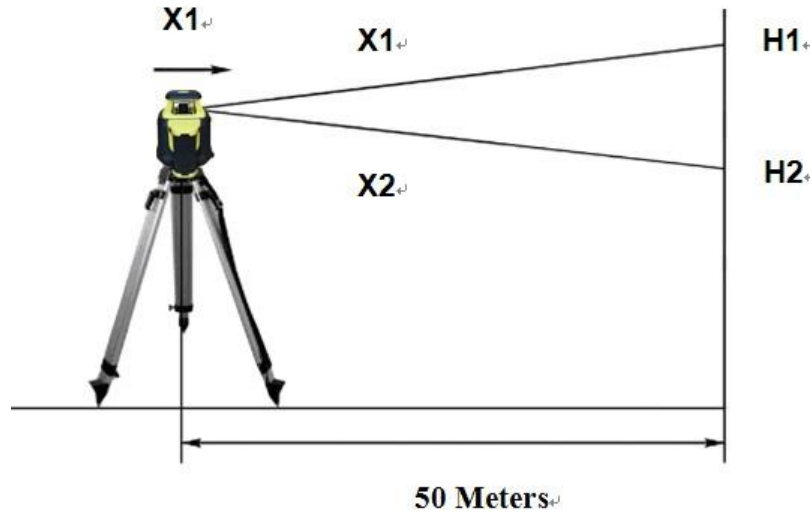

2. Allow the unit to level and begin rotating. Mark the beam position on the wall or scale plate as H1 and turn off the unit.

3. Loosen the tripod screw, rotate the Unit 180° and re-secure it on the tripod, (do NOT change the height) Turn on the unit.

4. Allow the unit to level and rotate. Mark the beam position on the wall or scale plate as H2.

**The difference between the value of H1 and H2 should be less than 0.39 inches (10mm).**

5. Repeat the same process to check your Y (Handle area) axis. Again, the difference between the values of the two measurements should be less than 0.032 inches (10mm).

6. If the difference in either axis is more than 0.026 inches (8mm), the unit should be sent to your authorized dealer for service/calibration.

## Horizontal-line checking.

Place the unit on a tripod between Wall A and B and put the tripod near Wall A. Distance from the center of the tripod to Wall A should be no more than approx. 1.5 feet (0.5m) and to Wall B approx. 100 feet (30m). (Follow the instructions on illustration). Switch the unit on.

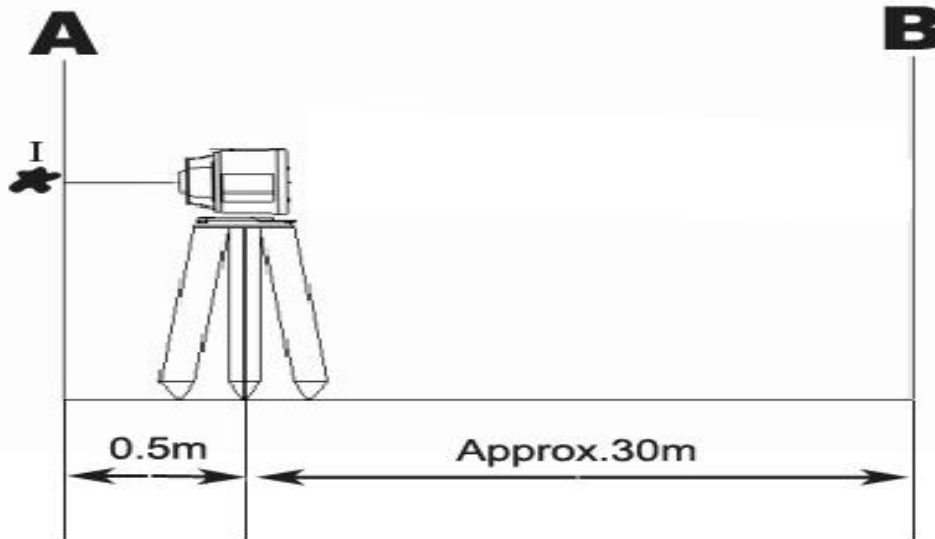

After leveling, direct the laser beam onto Wall A. Mark the center point of the laser beam on the wall (Point I)

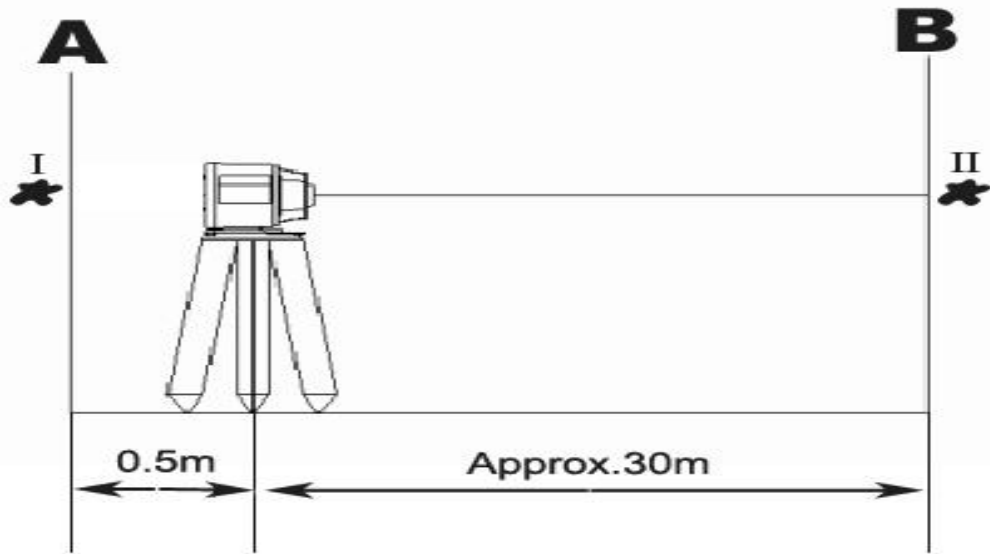

Turn the unit horizontally 180°. (Without changing the height). After leveling, direct the laser beam onto Wall B. Mark the center point of the laser beam on the opposite Wall B (Point II).

While the unit is still on the tripod, move the tripod to Wall B (do NOT turn the instrument). Turn on the unit and let it level.

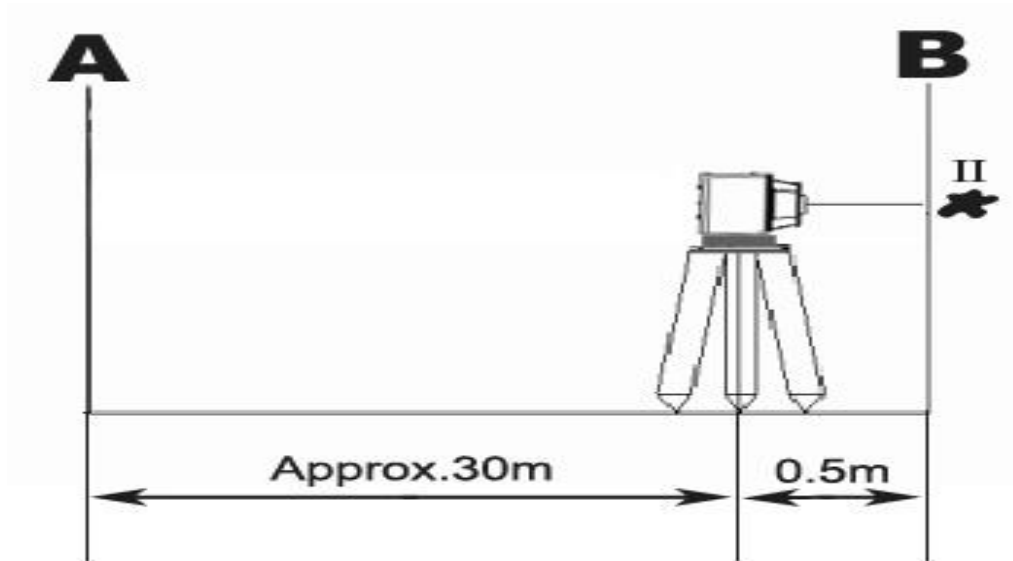

After leveling, align the height of the unit by using a tripod or by underlying if necessary. The center point of the laser beam is now projected exactly where the previously marked point II on Wall B was.

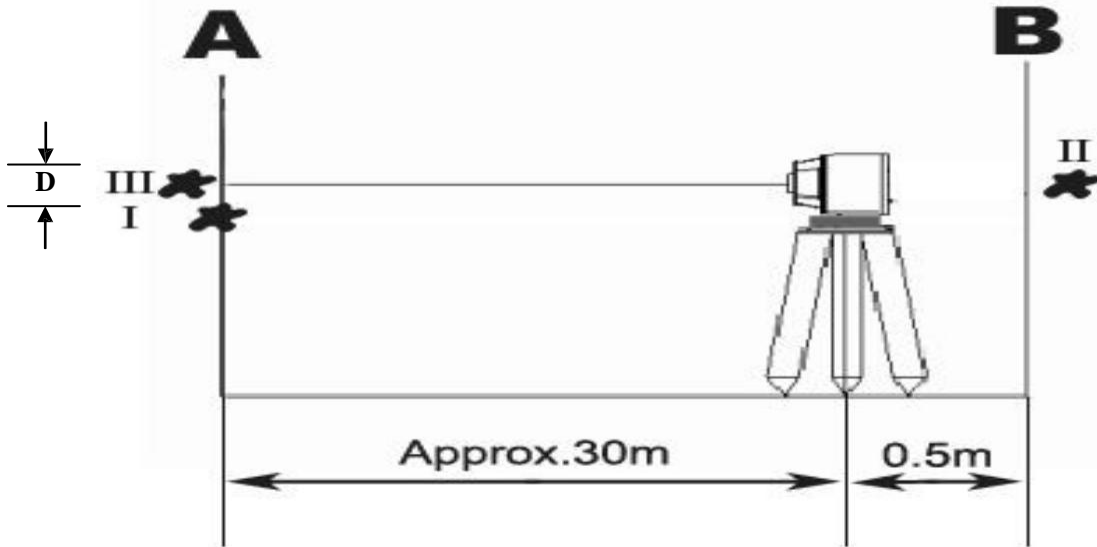

Rotate the unit by  $180^\circ$  without changing the height. Allow it to level and mark the center point of the laser beam on Wall A (point III). Take note that point III is as vertical as possible above or below point I.

The difference (D) of both marked points I and III on Wall A amounts to the actual deviation of the plumb up beam.

**D-value should be less than 0.15" (4mm).**

# Technical Specifications

Accuracy:	15 arc seconds (+/-1mm/10m)
Self leveling range:	±5°
Operation range(With detector)	1,650 feet (500m) with detector (Diameter)
Four head speeds:	0, 60, 300, 600 R. P. M.
Four scan widths:	10°; 45°; 90°; 180°
Bright, visible beam:	Wavelength 635nm: Class II
IR Remote control:	Available distance: 65 ft. (20m)
Operation temperature:	-4°F~122°F (-20°C~50°C)
Power supply:	DC 4. 8-6V (4xsub-C NI-MH battery or 4xsub-C Alkaline battery)
Continuance working time:	Approx. 40 hr.(Ni-MH) Approx. 30 hr(Alkaline)
Waterproof and dustproof:	IP 55
Dimension:	6.2" (L) X 6.2" (W) X 7.2" (H) (160 X 160 X 185mm)
Weight:	5.9 Lb (2.7kg)